

Bihler GmbH Keeps Firm Hold on Customers by Delivering Manuals with Impressive Technical Illustrations

Using Arbortext® IsoDraw®—in combination with the Unigraphics® NX™ CAD system—Bihler GmbH sees tremendous productivity boost in Technical Publication process.

“Satisfied customers”—this has been Bihler company’s main priority ever since Otto Bihler established the company in 1953. From its modest beginnings in a small workshop with three employees, Bihler rapidly evolved into a world leader in supplying forming, assembly and welding technologies. Today, thousands of companies in more than 50 European, Asian and American countries, representing a diverse range of industries (automobile manufacture, electric industry, medical engineering, etc.), rely on the expertise of Bihler’s 900 highly motivated employees—their experience, their quest for innovation, and the ground-breaking machine and system solutions that they develop.

To guarantee 100% customer satisfaction in manufacturing today, companies not only need to offer great products; they also must deliver easy-to-use, 100% accurate documentation on how to use these products. Customer satisfaction, to an ever-larger extent, depends on the quality and user-friendliness of the product manuals; the user must be able to quickly find and understand all information required for assembling, installing, operating, or repairing a machine. If the consumer can’t assemble or use the product because of difficult or inaccurate documentation, there’s a good chance it will be replaced by another product having clearer instructions.

Product manuals that include high-quality technical illustrations help to achieve this goal. Adding perspective illustrations to technical manuals brings a large number of benefits. In many cases, illustrations help to convey a message more clearly than text. And when using illustrations, less descriptive text may be needed. For companies that ship products internationally, manuals with more graphics than text result in lower translation costs, and reduce the risk of errors. However, the creation of technical illustrations is traditionally very time-intensive, and companies do not want to run into the danger of delaying product releases because the documentation is not ready.

The Bihler company, taking these considerations into account, restructured its documentation workflows in 2004. “By using spatial representations in our documentation, product descriptions become much clearer and easier to understand. In other words, the quality of our documentation is increased,” reports Klaus Pühler, head of documentation at Bihler. “However, we need to produce more than 100 illustrations per month, plus revisions of existing graphics. This workload was very often hard to cope with before we changed our processes.”

In 2004, Bihler product development implemented the Unigraphics 3D CAD System and began to explore the possibility of using existing 3D data for technical documentation purposes. This strategy

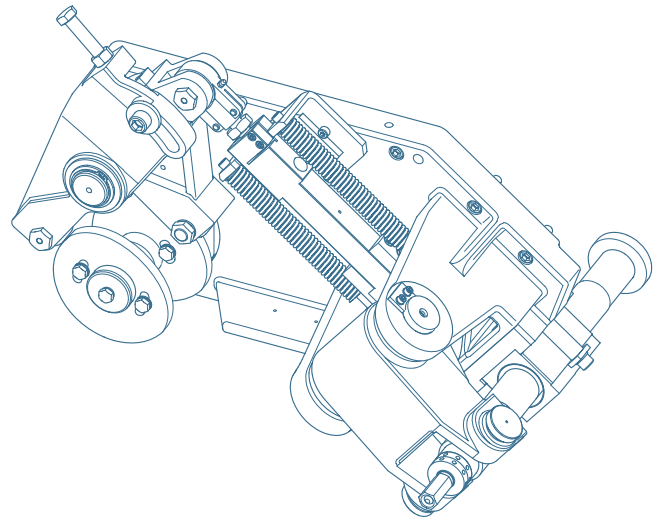

The above illustration—created from a 3D model designed in Unigraphics NX CAD system—shows the central mandrel of the Bihler GRM 80P punch-bending machine.

is becoming more and more common in the industry, since the reuse of 3D CAD data seems to offer a huge savings potential; why draw everything from scratch when the data has already been fully drawn in the CAD system?

Without a dedicated Technical Illustration solution, however, this approach proved to be easier said than done. First, the application infrastructure and process environment at Bihler had to be restructured in order to guarantee a workflow that would, in fact, allow for the assumed savings potential. As well, the technical publications department at Bihler, at that time, was working with

“The tremendous time savings we get through reusing our 3D CAD data with the help of Arbortext IsoDraw allow us to have our manuals ready when the product is ready to be launched. In addition, we can create more illustrations in less time and spend more effort on the quality of these. As a result, the overall quality of our technical manuals is increased.”

—Klaus Pühler,
Head of documentation, Bihler GmbH

three popular, yet very different graphics applications, each having a specific purpose (one for graphics, another for the spare parts catalogs, and a third for the operation manuals).

Traditionally, the Technical Publications department at Bihler always had its own CAD station for repurposing engineering drawings for their illustration tasks. In the “old days” of 2D CAD, the illustrators worked with flat, 2D geometries that they retrieved from the system via the DXF and HPGL formats. Exploded views were only used for the spare parts catalog, and those illustrations still had to be drawn 100% manually.

With the advent of 3D, however, the whole process was turned upside down. Reusing the 3D data to create more perspective drawings would require a lot of preparatory effort. In order to use the files in the existing graphics programs, the desired parts would first have to be placed in isometric perspective and in the position required for the technical illustration, and then exported to 2D. Also, when additional views, such as an exploded view, were needed, this work would all have to be prepared in CAD. The technical publications department had their own 3D workstation, but these preparations would require some engineering skills and experience. And on top of that, they are time-consuming, as well.

Technical illustration volume at Bihler:

- On average, Bihler develops two new machine types each year.
- Existing machine types are further developed on a regular basis, so there are almost monthly changes to the existing types.
- Depending on its type, a machine, such as the GRM 80P punch-bending machine, consists of 600-800 individual parts; however, this figure relates only to the machine parts of the basic machine without NC controls and slide units.

The tremendous preparatory effort, however, is only half of the story. After the exports have been done, the actual work of the illustrator starts. The 2D illustrations need to be worked on in the graphics application. Usually, this work effort begins by manually deleting a large number of polylines that result from a typical CAD system translation. This effort alone can take up to several hours, depending on the complexity of the illustration. Next comes the more artistic part: applying stylistic devices that are required to convey the specific message of a good technical illustration. Thick and thin lines must be applied correctly; threads (which cannot be created in the CAD system) may need to be added to bolts; and hands, tools, callouts, and magnifiers may also need to be drawn.

“Well, the assemblies already existed in the CAD system, but making them usable for us in technical documentation still was much more of an effort than we initially thought,” says Klaus Pühler. “We therefore started to research for a tool that could bridge the gap and make it easier for us to manipulate the CAD models. Also, we

wanted to have one tool, only, that could address our illustration needs and could replace the existing graphics applications we were using so far.”

As a result, soon after the implementation of Unigraphics NX4, Bihler purchased several seats of Arbortext IsoDraw from PTC to serve as the standard toolset for all technical illustration requirements. Here’s how the new process flows:

- The illustrators in the tech pubs department export entire 3D assemblies to IGES or STEP format; no further preparation work is required.
- The illustrators now can process the 3D files without having to further access the CAD station. They can read entire assemblies or parts selectively in Arbortext IsoDraw CADprocess—and thus in an environment that not only is typical of a graphics application, but also is much more familiar to the illustrators than is a CAD system.
- A treeview window allows illustrators to select the parts they need, and they can manipulate (explode, rotate, cut) them in the so-called 3D Window of Arbortext IsoDraw according to their needs. This can be done intuitively with just a few mouse clicks.
- Once the 3D graphics are ready for conversion, a push of a button is sufficient to convert the 3D graphic into a high-quality technical illustration: line weights are applied automatically and hidden lines are removed.
- Now the illustration is ready for artistic finishing, such as adding hands or tools. This final step is fast and easy, as Arbortext IsoDraw offers a wide range of dedicated tools.

With the new, optimized workflow consisting of the combination of Unigraphics NX with Arbortext IsoDraw CADprocess, the productivity in the technical publications department is expected to increase dramatically, especially in the area of creating exploded view drawings for the spare parts catalog.

Highly Graphical Technical Manuals: Making Customers Happy

Using the Unigraphics CAD system in combination with Arbortext IsoDraw results in a publishing solution that is—just like Bihler’s products—state-of-the-art, enabling the company’s technical publications department to save time and money, and create more attractive, more useful, and more effective product manuals and technical publications. Even better, this publishing solution helps the company achieve its number one objective: More Satisfied Customers.

Copyright © 2008, Parametric Technology Corporation (PTC). All rights reserved. Information described herein is furnished for informational use only, is subject to change without notice, and should not be construed as a guarantee, commitment, condition or offer by PTC. PTC, the PTC logotype, Arbortext IsoDraw, and all PTC product names and logos are trademarks or registered trademarks of PTC and/or its subsidiaries in the United States and in other countries. All other product or company names are the property of their respective owners.

To learn more about how Arbortext can help your company create and delivery high-quality product information, please visit our website at: <http://www.single-sourcing.com/>

3260-Bihler CS-0308