

Atlas Copco Easily Quantifies Its Return on Investment from Installing Arbortext® IsoDraw®

Leading Maker of Rock Drills Sees Fast Improvement in Illustration Quality and Cost Reduction with PTC's Service Information Solution

As the Group Leader of Technical Documentation at Atlas Copco Rock Drills for Surface Drilling Equipment (SDE), based in Örebro, Sweden, Tommy Larsson has spent six years managing technical documentation and illustrations that support the long-term operation and service of surface drill rigs produced by Atlas Copco. In order to reduce costs and improve the quality of that product information, Mr. Larsson recently evaluated new alternatives to produce better illustrations with fewer resources. Here is a brief description of the evaluation process.

Understanding the Existing Illustration Process

Before looking at new solutions to improve the illustration process at Atlas Copco, it was important to determine where improvements could be made—both from an image quality and a financial perspective. The company was already using the global 3D CAD (computer-aided design) standard of Pro/ENGINEER® from PTC for their engineering design processes.

In most areas of development, the company was using various desktop graphics software to create their illustrations from vector-based CAD output. In their experience, this outdated illustration software proved to be time-consuming, unable to produce rich, quality illustrations, and not linked to actual CAD data, which means that, as engineering designs changed, illustrators had to manually identify the changes and re-create those illustrations to stay up to date.

In some instances, Atlas Copco used outsourced illustration resources, which proved to be both costly and inconsistent. When outsourcing illustrations to a large graphics company, the cost per illustration became excessive. The company was able to rely on the output of an individual contractor, but unfortunately that resource was on the verge of retirement. Overall, the outsourcing process worldwide caused even greater disparity between the quality and presentation of illustrations in product support documentation.

Arbortext IsoDraw: Improving the Process of Producing High-quality, Consistent Illustrations

Recently, Atlas Copco decided to implement an advanced, automated graphic illustration solution—Arbortext IsoDraw from PTC—that not only produces high-quality, fully accurate illustrations, but since the software is directly integrated with the company's CAD software (Pro/ENGINEER), illustrations are updated automatically as product designs are modified.



The Atlas Copco Surface Drilling Equipment group supports development centers in Garland and Örebro, Sweden; Yokohama, Japan; and Nanjing, China.

This new solution spans all the geographies that support the Surface Drilling Equipment (SDE) group, including Garland and Örebro, Sweden; Yokohama, Japan; and Nanjing, China. With Arbortext IsoDraw as the SDE technical illustration standard, the team now delivers a consistent presentation of all illustrations, ensures compatibility between illustrators regardless of location, associates illustrations to CAD data to automate updates when engineering designs change, and eliminates outsourced illustrations altogether. Additionally, Arbortext IsoDraw enables illustrators to create, from scratch, the same quality of drawings—even when no CAD data is available—and import other CAD file formats when supplier data needs to be incorporated.

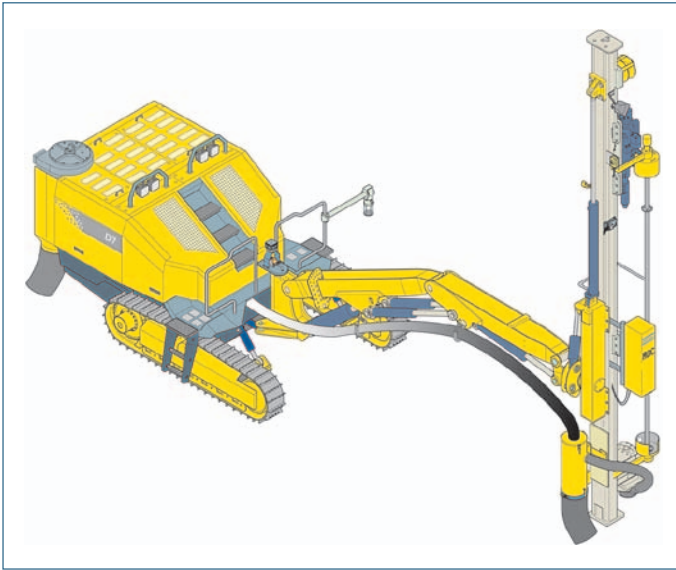

Global illustrators are all using Arbortext IsoDraw to produce consistent 2D and 3D illustrations regardless of original 3D CAD format.

The new standard solution enables illustrators to produce higher-quality, more-accurate illustrations that heighten both the customer and technician experience throughout the lifespan of the Atlas Copco drilling equipment. The next step is to manage the illustrations and their 3D CAD relationships in Atlas Copco's PLM (Product Lifecycle Management) system using Windchill®, the PLM solution from PTC, which will bring additional benefits to Atlas Copco's worldwide process chain. (The benefits of adding Windchill were not taken into account in the ROI calculation.)



To learn more about how Arbortext can help your company create and delivery high-quality product information, please visit our website at: <http://www.single-sourcing.com/>

Measuring the Financial Benefits

As with all new Information Technology (IT) investments, Mr. Larsson was compelled to produce a return-on-investment (ROI) assessment that would indicate the financial benefits of the investment, as well as the quality improvements. Because the Swedish processes were the most accessible to evaluate, Mr. Larsson estimated the ROI based on the cost savings to the Garland and Örebro offices only.

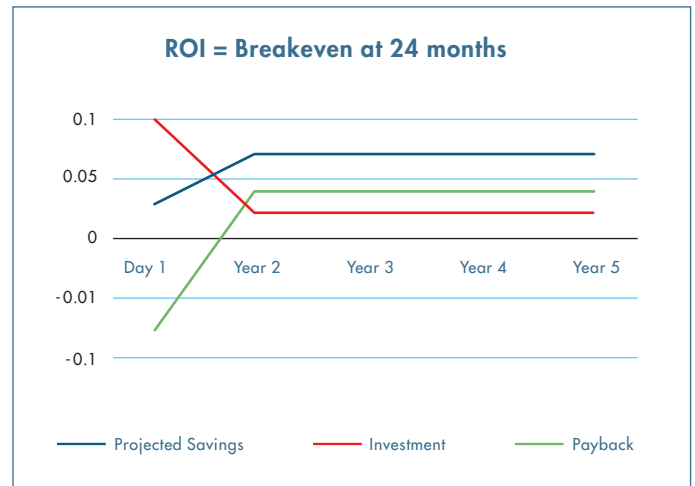

- Atlas Copco's Surface Drilling Equipment (SDE) group realized a 1.3-hour savings in file-handling per illustration, involving more than 1,350 illustrations per year, after eliminating all outsourced illustrations
- Payoff is calculated in 24 months, using Sweden's reductions, which include a 4-month learning "ramp"
- 5 Licenses – 2 local, 2 global and 1 USB local – will serve all geographies; plus, training for 5 students

The Results

- All illustrators are using the same software to produce consistent 2D and 3D illustrations
- Higher-quality illustrations for technical documentation are available almost immediately to improve the customer experience
- At 24 months, the financial benefits will have covered the costs of the software

Biography

- Mr. Larsson has spent more than 13 years at Atlas Copco in various roles and has gained first-hand knowledge of the value of quality product information. Mr. Larsson has held the positions of Assembler of Drill Rigs, Parts Preparation, and Documentation.

© 2010, Parametric Technology Corporation (PTC). All rights reserved. Information described herein is furnished for informational use only, is subject to change without notice, and should not be construed as a guarantee, commitment, condition or offer by PTC. PTC, the PTC logotype, Arbortext IsoDraw, Windchill, Pro/ENGINEER, and all PTC product names and logos are trademarks or registered trademarks of PTC and/or its subsidiaries in the United States and in other countries. All other product or company names are the property of their respective owners.